

Engineered for strength and reliability with an aesthetically appealing architectural look, the Champion EMW-LED is ideal for any commercial environment where emergency units are required. With its heavy duty lens, superior circuitry, and gaskets to seal and protect the unit, the Champion EMW-LED braves the most adverse conditions from extreme weather and high-vandalism locations to heavy industrial applications.

Model: \_\_\_\_\_ Date: \_\_\_\_\_  
Accessories: \_\_\_\_\_  
Job Name: \_\_\_\_\_ Type: \_\_\_\_\_

**FEATURES**

- Conforms to IP66 rating for wet and hose down locations
- Die-cast aluminum backplate, fully gasketed and sealed with durable powder-coated finish
- Fully adjustable high intensity LED lamps
- Standard LED with narrow beam (12°), optional wide beam LEDs (58°) available
- Standard 6V 8 watts, optional 25 watts unit for extended run times of 4 hours or remote capacity
- Impact resistant, polycarbonate shield offers extreme protection
- Guardian Self-Test/Self-Diagnostics (G2) standard
- Maintenance free NiMH (nickel metal hydride) battery
- AC lockout for ease of installation and installer protection
- Low voltage disconnect eliminates deep discharge
- Brown-out protection
- Optional internal thermostat controlled battery heater for cold location installs (-20°C) (IH1 or IH2)
- Optional I-beam and pole mounting bracket available
- Universal J-box mounting system with top mounted conduit entry for ease of install
- Suitable for ceiling back mount installation
- 120/277V dual primary, 50/60Hz input
- Standard finishes: Satin Aluminum or Bronze
- Assembled in the U.S.A.



**APPLICATIONS**

- Schools and public facilities
- Secure areas/prisons
- Sports arenas
- Warehouse and freezer storage facilities
- Parking garages
- Marine locations
- Heavy industrial facilities
- Hosedown areas

**WARRANTY**

Any component that fails due to manufacturers defect is guaranteed for 5 years with a separate 5 year pro-rated warranty on the battery. The warranty does not cover physical damage, abuse or instances of uncontrollable natural forces. See the full Exitronix warranty document for detailed information.

**ORDERING INFORMATION Example: CP-EMW-8-LED-SA-WL**

Series	Watts	Lamps	Finish	Options (Factory Installed)
CP-EMW	8 = 8 Watts	LED = 3.6W LED	SA = Satin Aluminum	IH1 = Internal Battery Heater 120VAC
	25 <sup>1</sup> = 25 Watts		BR = Bronze	IH2 = Internal Battery Heater 277VAC
				TRH = Tamper Resistant Hardware
				WL = Wide Beam 58° LEDs
				<b>Accessories<sup>2</sup> (Field Installed)</b>
				IHB = I-Beam and Pole Mounting Bracket
				TRHT = Tamper Resistant Tool
				WG-90 = Wire Guard (Back Mount)
				Ren1G-WP = Renegade LED Lamp PAR 18 3.6W, Gray
				Ren2G-WP = Renegade LED Lamp PAR 36 3.6W, Gray
<b>Notes</b>				
<sup>1</sup> Provides extended run time of 4 hours if no additional remotes are wired				
<sup>2</sup> Order as separate line item				

## CONSTRUCTION

The Champion EMW-LED is constructed with a heavy-duty, fully gasketed die-cast aluminum backplate with a durable powder-coated finish. The cover is made from UV stable, vandal-resistant polycarbonate. A silicone gasket between cover and backplate ensures a water-tight, dust-free enclosure. The area around the universal knockouts is protected by a closed-cell neoprene gasket. The enclosure conforms to IP66 ratings ensuring that the product can be installed in outdoor applications where significant water or dust may come in contact with the fixture as well as hose down applications.

## ILLUMINATION

Two fully adjustable lamp heads allow for maximum light to be delivered to the path of egress. The Champion EMW-LED offers two 3.6W Renegade Performance LED heads meeting 207 total lumens per head with a crisp white LED color temperature of 5100K. Standard LEDs have a narrow (12°) beam spread. Optional wide beam spread LEDs (58°) available.

## ELECTRICAL

### Input

Dual-voltage input 120 or 277VAC at 50/60Hz.

### Sealed Nickel Metal Hydride Battery – NiMH

Extronix nickel metal hydride batteries are maintenance-free with a life expectancy of 15 years. NiMH batteries perform optimally in temperatures ranging from 0-40° C.

### Electrical Components

The Champion EMW-LED utilizes a pulse switching charger that is up to 70% more efficient than traditional constant voltage chargers. The charger is a fully automatic, current limited charger with solid state, line-latched, low voltage disconnects protection. All components used in the circuitry are temperature compensated.

### Emergency

The Champion EMW-LED will operate for a minimum of 90 minutes during a loss of power with a 48 hour maximum recharge time for the battery.

### Brownout Circuit

The brownout circuit monitors the flow of AC current to the unit and triggers the emergency lighting system once a set reduction of AC power occurs. This dip in the voltage will cause many fixtures to extinguish, causing loss of normal lighting even though a total power failure has not occurred.

### Low Voltage Disconnect

When the battery's terminal voltage falls below predetermined levels, the low-voltage circuit disconnects the emergency lighting load. The disconnect remains in effect until normal power is restored, preventing deep battery discharge and improving the life of the battery. The disconnect will also automatically reconnect the load circuit once the battery voltage returns to a normal value after charging.

### Overload and Short-Circuit Protection

The solid-state overload monitoring system in the DC circuit disconnects the lamp load from the battery should excessive wattage demands be made and automatically resets when the overload or short-circuit is removed. This overload current protective characteristic eliminates the need for fuses or circuit breakers for the DC load.

### Test Button

The easily accessible test button allows for manual verification of proper operation of the transfer circuit and emergency lamps.

## INSTALLATION

The Champion EMW-LED is suitable for surface wall mounting and includes universal J-box knockouts, and a conduit entry plug in the top of the enclosure. Corrosion-resistant stainless steel hardware is standard; tamper resistant hardware is available. Optional I-beam mounting bracket is available for mounting to poles, I-beams, or strut metal framing.

## IP66 RATING

IP66 rating provides complete protection against contact with live parts inside the enclosure and against the ingress of dust. Water projected in powerful jets against the enclosure from any direction shall have no harmful effects.

## GUARDIAN SELF-TESTING/SELF-DIAGNOSTIC (Standard)

The Guardian circuit continuously monitors the operating condition of the AC power, battery supply voltage, emergency lamp continuity and charging circuit.

The purpose of this option is to provide visual signaling in response to a possible fault. If a failure is detected, visual status will occur immediately via the CHARGER LED and/or the BATTERY FAULT LED. The LEDs will stay illuminated until the fault is corrected.

The Guardian circuit also monitors the transfer circuit as well as performing automatic code compliant testing. The Guardian circuit will perform a 5 minute discharge and self-test every 30 days. A 90 minute discharge and self-test is performed every 6 months.

## INTERNAL HEATER (OPTION: IH1 OR IH2)

The internal heater is a voltage specific thermostat regulated heater that is designed to extend the operating temperature range of this unit down to -20° C (-4° F).

## TAMPER RESISTANT HARDWARE (OPTION: TRH)

Tamper resistant hardware adds an additional layer of protection to the unit, preventing unwanted access to the interior of the unit or removal of the face plates.

## MADE IN THE USA

Made in the USA and in full compliance with the American Recovery and Reinvestment Act of 2009 (ARRA) requirements and Buy American provisions.

## CONFORMANCE TO CODES AND STANDARDS

The Champion EMW-LED is C-UL-US listed and meets or exceeds the following: UL 924, NEC requirements, NFPA 101 and IP66 ratings.

## WARRANTY

Any component that fails due to manufacturer's defect is guaranteed for 5 years with a separate 5 year pro-rated warranty on the battery. The warranty does not cover physical damage, abuse or acts of God. Manufacturer reserves the right to charge for such repairs if deemed necessary.

## DIMENSIONS

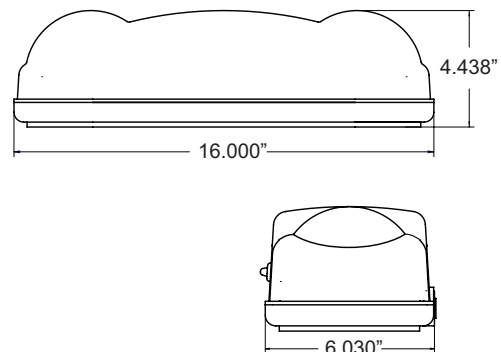

**SAMPLEPHOTOMETRICS**

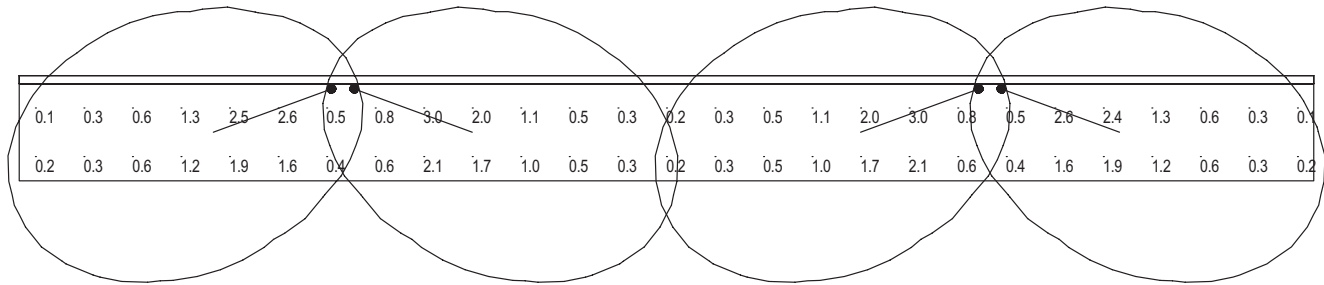

**CP-EMW-LED-58**  
**58 Degree LED**  
**40' Spacing**  
 7.5" Mounting Height  
 6' Wide Egress Path

Room Reflectance  
 Ceiling: 80  
 Walls: 50  
 Floors: 20

Avg: 1.03  
 Max: 2.96  
 Min: 0.10  
 Avg/Min: 10.30  
 Max/Min: 29.60

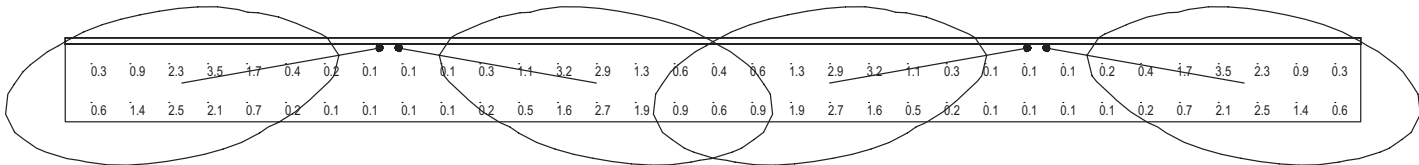

**CP-EMW-LED-12**  
**12 Degree LED**  
**50' Spacing**  
 7.5" Mounting Height  
 6' Wide Egress Path

Room Reflectance  
 Ceiling: 80  
 Walls: 50  
 Floors: 20

Avg: 1.05  
 Max: 5.30  
 Min: 0.10  
 Avg/Min: 10.50  
 Max/Min: 53.00

**OPTIONAL POLE / I-BEAM MOUNTING**

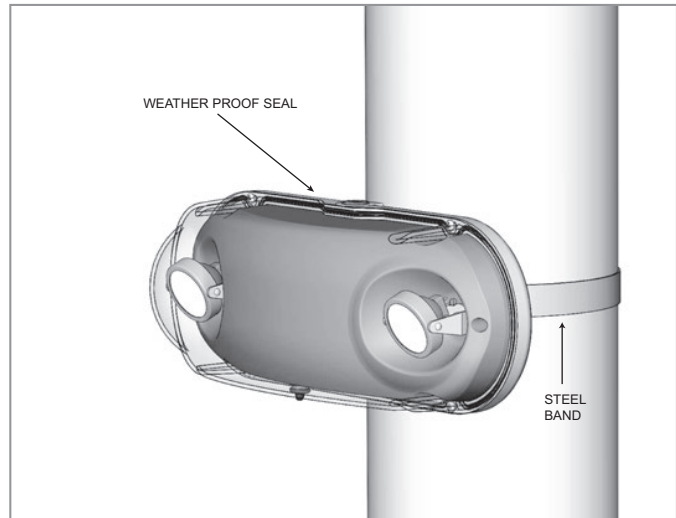
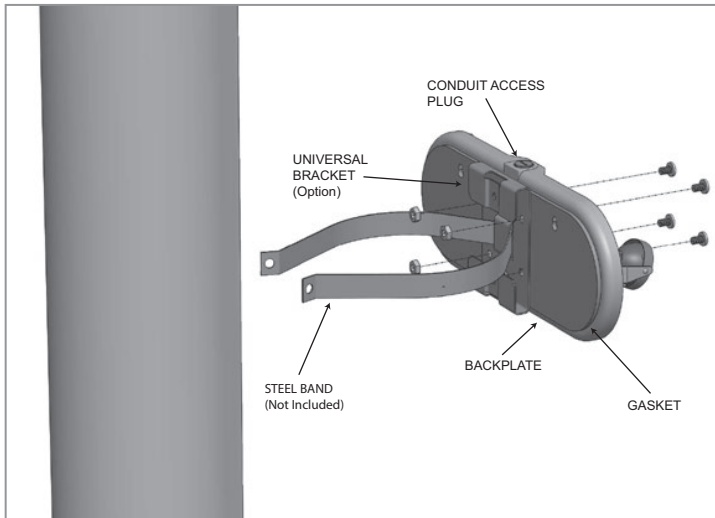

Specifications are subject to change without notice.  
 Installation must be performed in accordance with  
 Barron Lighting Group installation instructions.

10800249 10/17